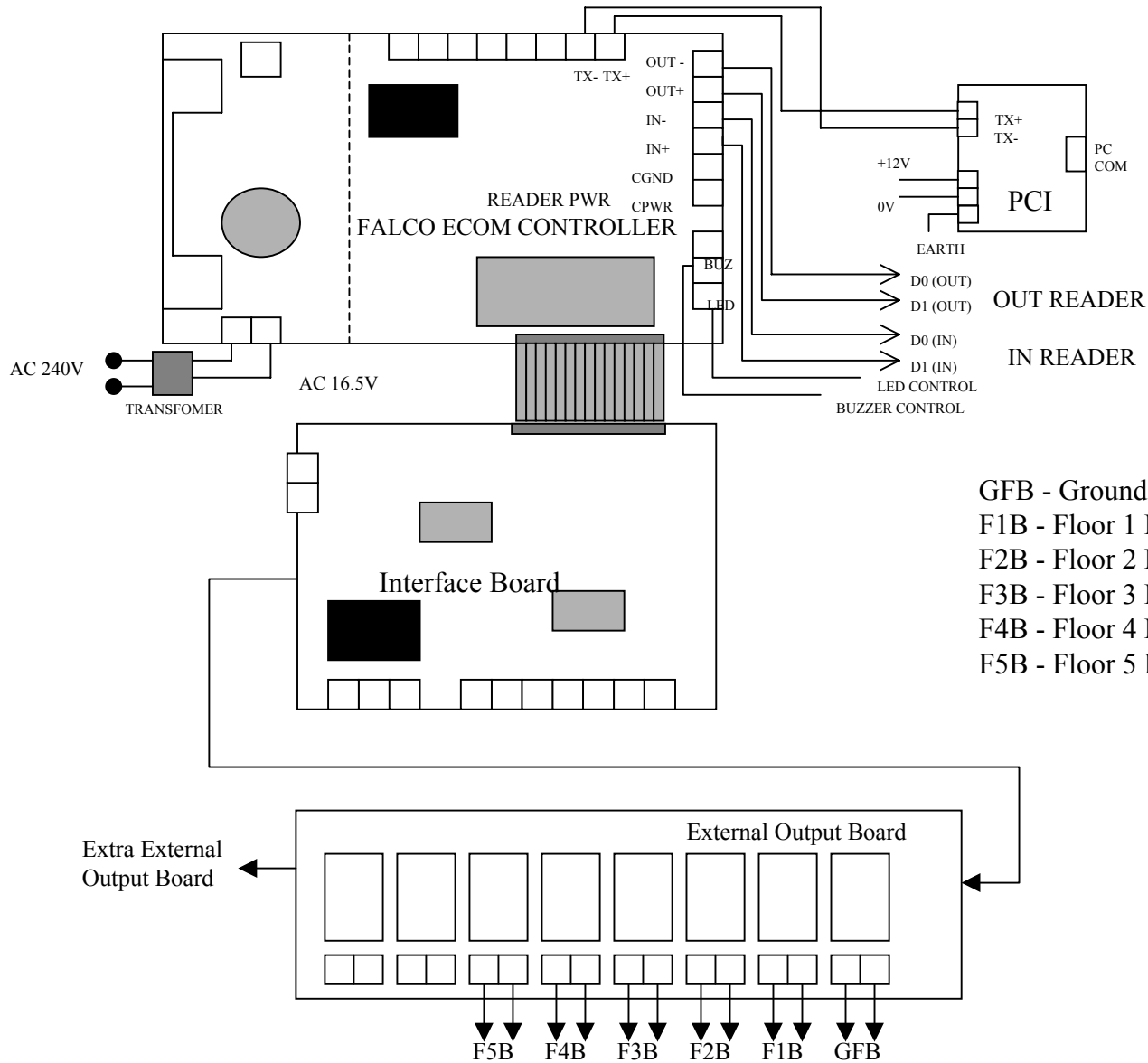

DIAGRAM FOR LIFT MODULE USING FALCO ECOM



- GFB - Ground Floor Button From Lift Controller
- F1B - Floor 1 Button From Lift Controller
- F2B - Floor 2 Button From Lift Controller
- F3B - Floor 3 Button From Lift Controller
- F4B - Floor 4 Button From Lift Controller
- F5B - Floor 5 Button From Lift Controller