

# MX300

## BRUSHLESS DC BARRIER GATE SYSTEM



- ✓ The running speed can be adjusted from 2.5s to 8s
- ✓ Arm can be quickly interchanged left or right
- ✓ Open the barrier gate by motor wheel when power off, automatically reset after power on
- ✓ Curved crank arm three-link movement structure, the operation is stable
- ✓ Auto Reverse Function (force adjustable)
- ✓ Motor added with anti-skid device
- ✓ Safe and reliable, motor upgraded with new precision cast steel material



Working Temperature (Motor): **-25°C ~ 60°C**  
 Rated Voltage: **DC24V**  
 Running Speed: **2.5s ~ 6s**  
 Rated Current: **9.5A**  
 Rated Power: **150W**  
 No-Load Speed: **1850rpm**  
 Rated Torque: **59.6N.m**  
 Relative Humidity: **≥ 85%**  
 Remote Control Distance: **≤ 50M (open place)**  
 IP Degree: **IP54**  
 Adaptation of Arm: **4 Meter Telescopic Arm**



## BRUSHLESS FORCE DISTANCE MOTOR MOVEMENT

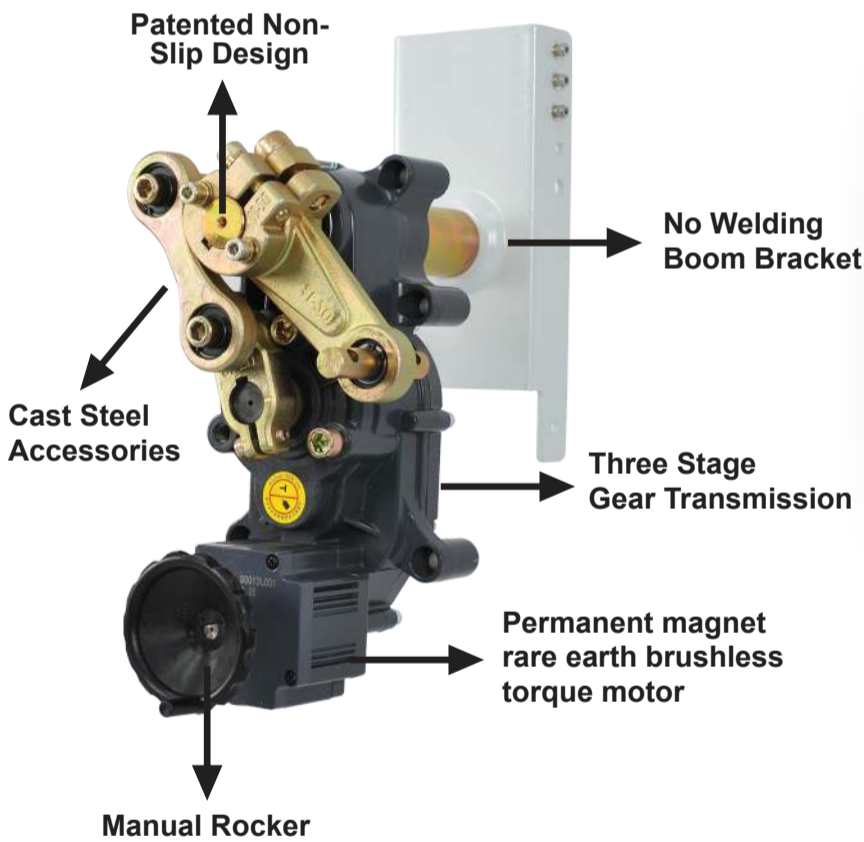

- ✓ High Performance, Many Interfaces, Strong functions, Fast Response, Large Memory and Stable
- ✓ Good stability and high reliability
- ✓ Can be completely intelligent
- ✓ Enables powerful data writing, fast processing and recall

## TELESCOPIC ARM DIMENSIONS

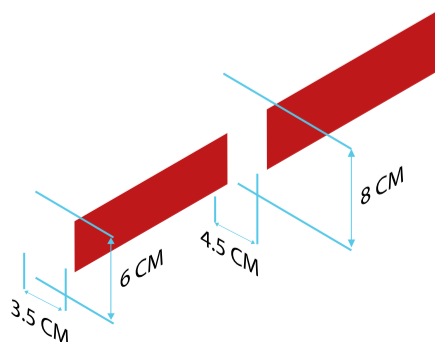

## REGULATED AND CONSTANT VOLTAGE DESIGNS

